

INSTRUCTION MANUAL

● PRODUCT DESCRIPTION

paul russells' tiltable integrated LED downlight combines a compact housing design with outstanding optical performance, ensuring excellent and even light output. It also boasts high power efficiency, resulting in an 85% energy saving when compared to traditional halogen lamps. There is no UV or IR light in the beam, and all of the products are CE, UKCA, and RoHS compliant.

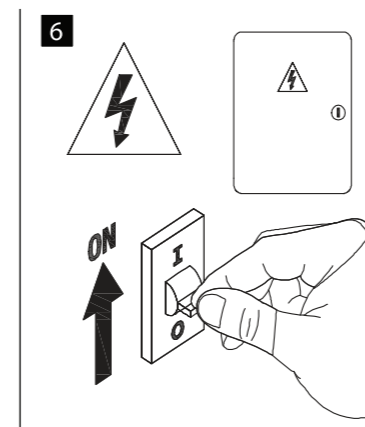
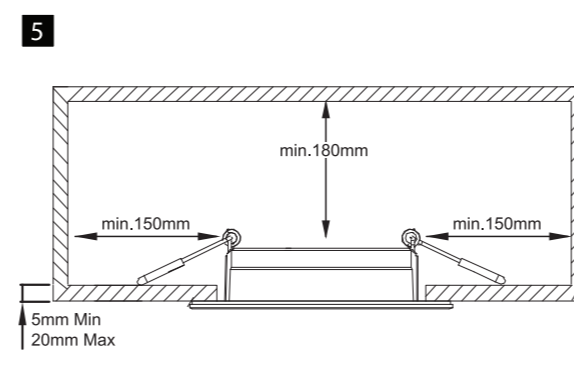
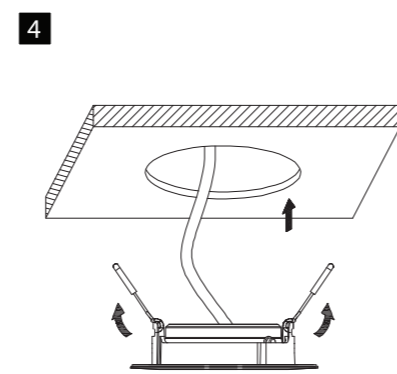
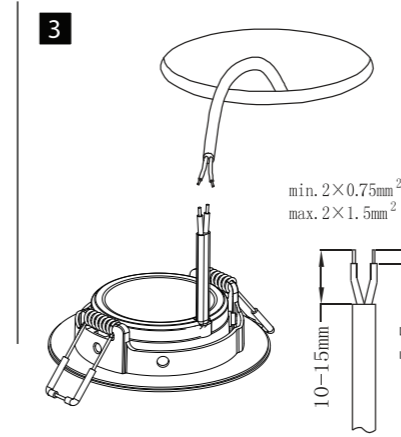
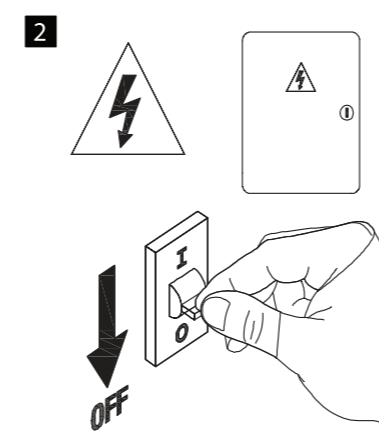
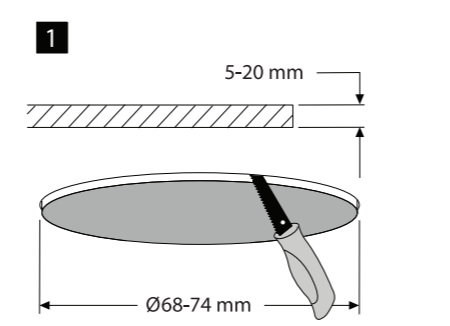
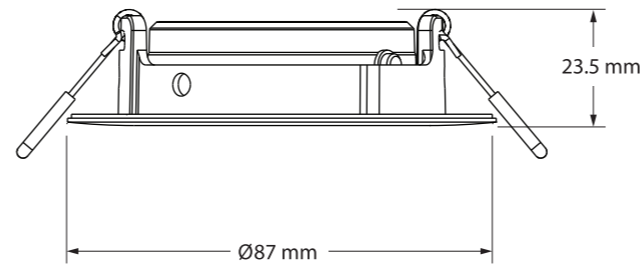

NOTE

- For indoor use only, keep it in a dry environment.
- The power supply must be disconnected during installation, maintenance, or light replacement. Ensure that the positive and negative electrode connections are correct before reconnecting the electrical supply.
- Do NOT attempt to disassemble the LED light.
- Do NOT touch the light while it is on or shortly after it has been switched off.
- LED light sources are non-replaceable.
- Do not open the fixture or loosen any screws, as it may affect the thermal performance of the LED light, shorten the LED's lifespan, or even damage the light source.
- Only install it on a suitable ceiling, and have the light installed by a qualified electrician.



If the external flexible cable or cord of this light is damaged, it must be replaced exclusively by the manufacturer, their service agent, or a similarly qualified person in order to prevent hazards.

